

# masterbath collection

6262MWMB-Le Magnifique

## SPECIFICATIONS

- All dimensions are plus or minus (maximum tolerance)
- Vita Bath reserves the right to make changes without notice.
- Copyright, all rights reserved.

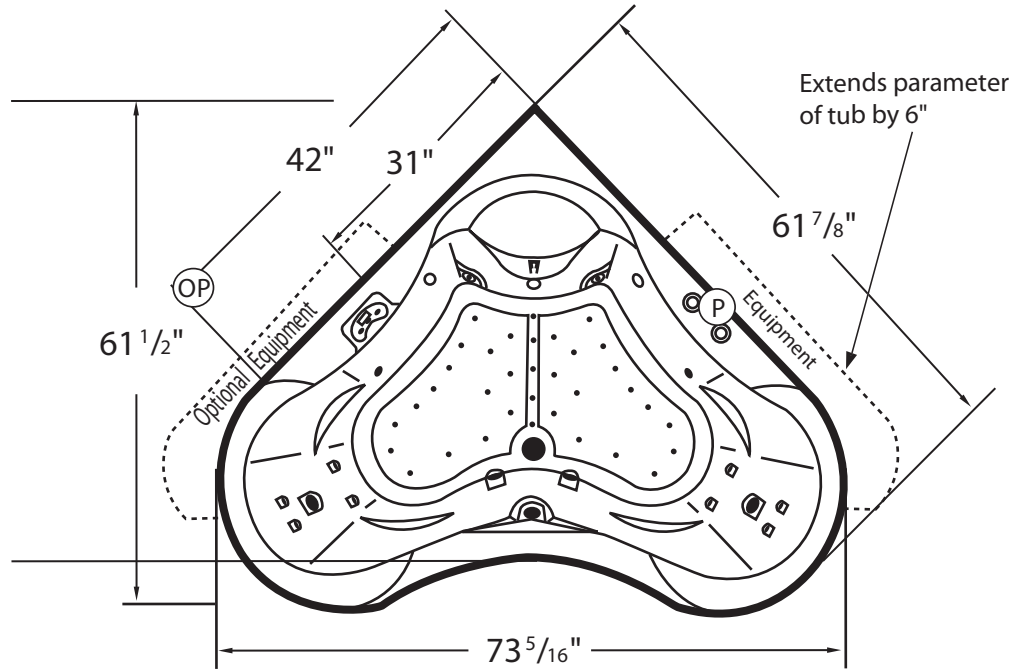

- MODEL: 6262 MWMB  
 SIZE: 61.5" x 61.5"  
 EST. CRATED WEIGHT: 360 lbs.  
 CRATED SIZE: 75" x 75" x 36"  
 AVERAGE FILL (gallons): 90  
 PUMP SIZE: 3 HP  
 HEATER: 1.5KW  
 ELECTRICAL: 220 V 30 Amp Circuit  
 MATERIAL: Acrylic reinforced fiberglass  
 STANDARD COLORS: White, Black, Bone, Almond, Biscuit, Linen, Inn. Blush, Sterling Silver  
 STANDARD FEATURES: VitAroma with Champagne Air, Waterfall, Electronic Control, Tub Filler, Spectra-Glo  
 JETS: Star Jets 2, Cluster Jets 8, Rotoswirl Jets 2, Vitassage Turbo Jets 2  
 AIR JETS: 35 Aero--ssage Jets  
 AIR CONTROL(S): 1  
 SUCTION FITTINGS: 2

TEMPLATE AVAILABLE

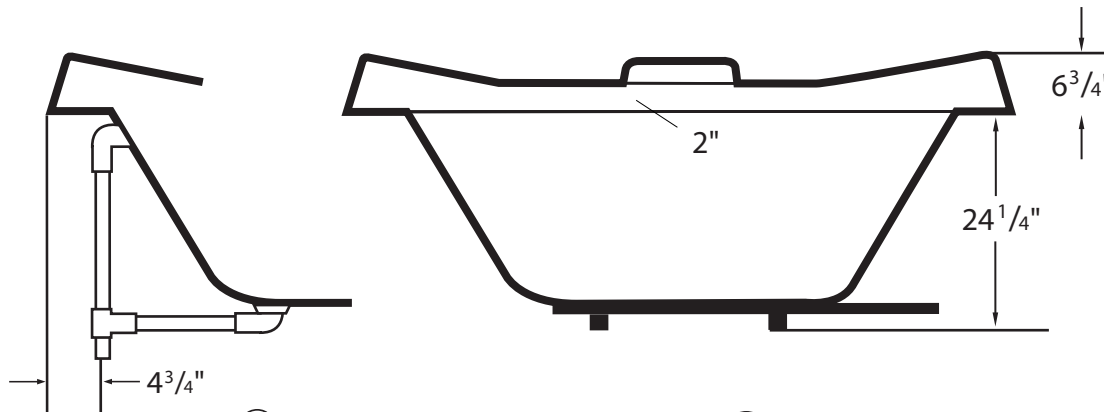

(P) Standard Pump Location

(OP) Optional Pump Location

Interior Depth	Interior Length Top	Interior Width Top	Interior Length Bottom	Interior Width Bottom
22 3/4	67	37 3/4	54	29 1/2

\* Except interior depth, all dimensions are approximations to the nearest inch.



A Division of DM Industries, Ltd.  
 2320 N.W.147th St., Miami, FL 33054  
 Tel: (305) 685-5739 / (888) 289-8482  
 Fax: (305) 688-9415 / (800) 785-5222  
 Web Site: <http://www.vitabath.com>