

INSTALLATION INSTRUCTIONS

Modello Rectangular Acrylic Air Bath Tub

- Install so that the security device, MANI-SD-A, is at least 2" above tub rim.

Components List:

- BM-TWP Ball Check Valve Jets
- MANI-SD-A Security Device
- MAN-A-4-AC Manifold
- Silver SLS+ Variable Speed Blower

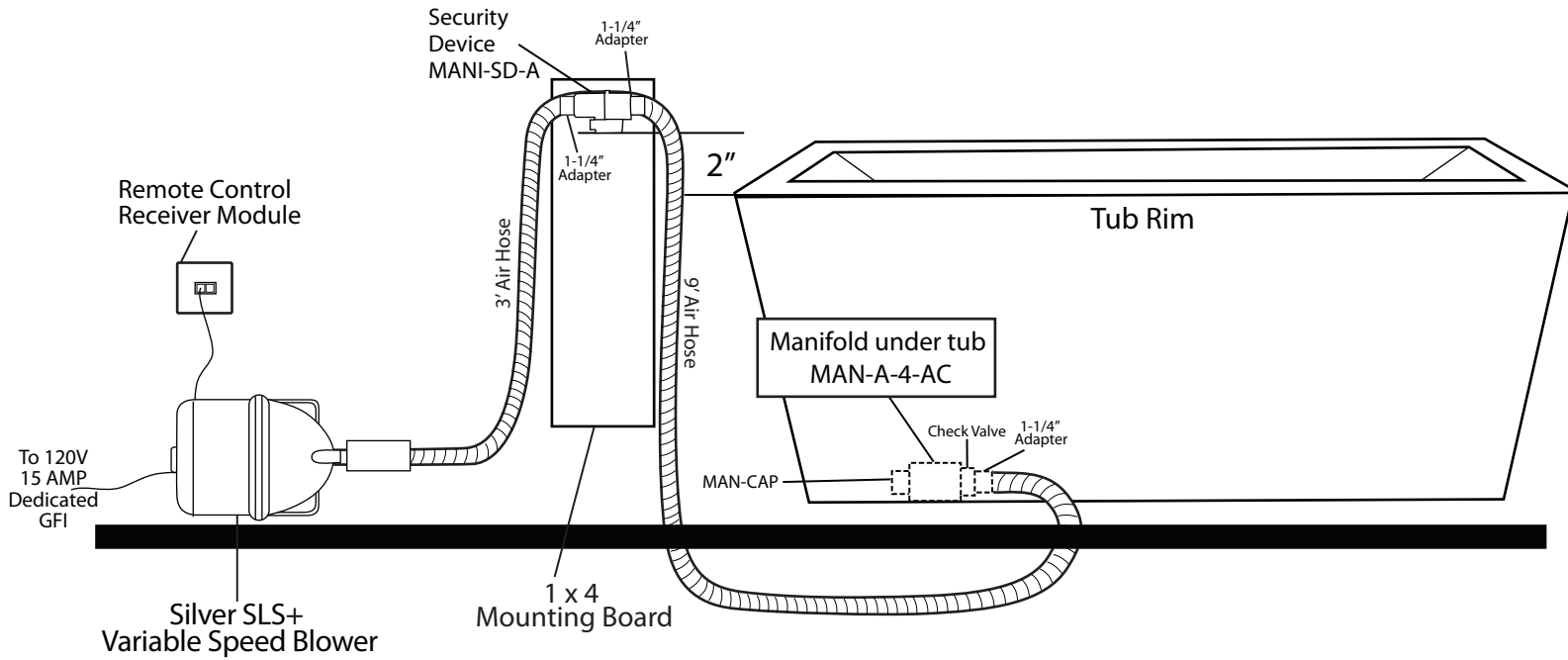

Features:

- (12) Maxi Air Jets with 24 openings



Elbows for white air jets

Tees for white air jets



Elbows for black air jets

Tees for black air jets

- Remote Control CG+/RTC-SENSOR-WP



12-15 year battery life

Inside of Bath

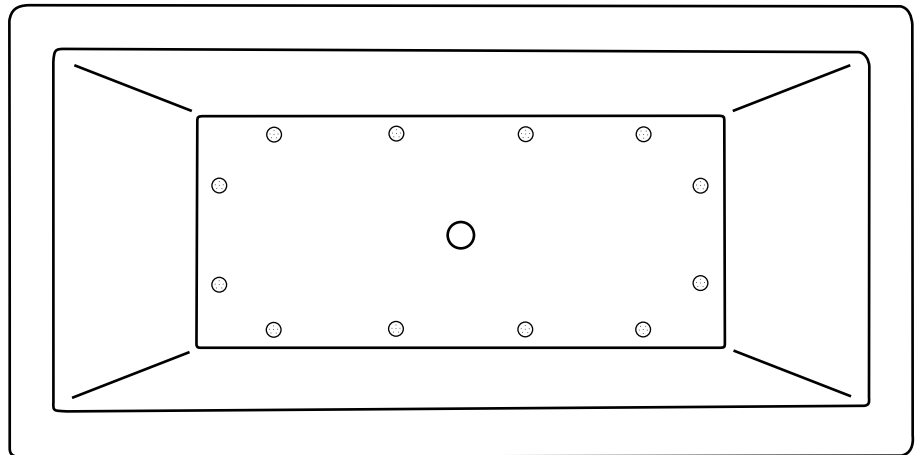

Modello Rectangular Acrylic Air Bath Tub

Tub Dimensions: 63-3/8" L x 31-3/4" W x 23-1/2" H

Tub Water Capacity: 91 gallons (to top of tub)

Tub Weight Uncrated: 126 lbs. Tub Weight Crated: 226 lbs

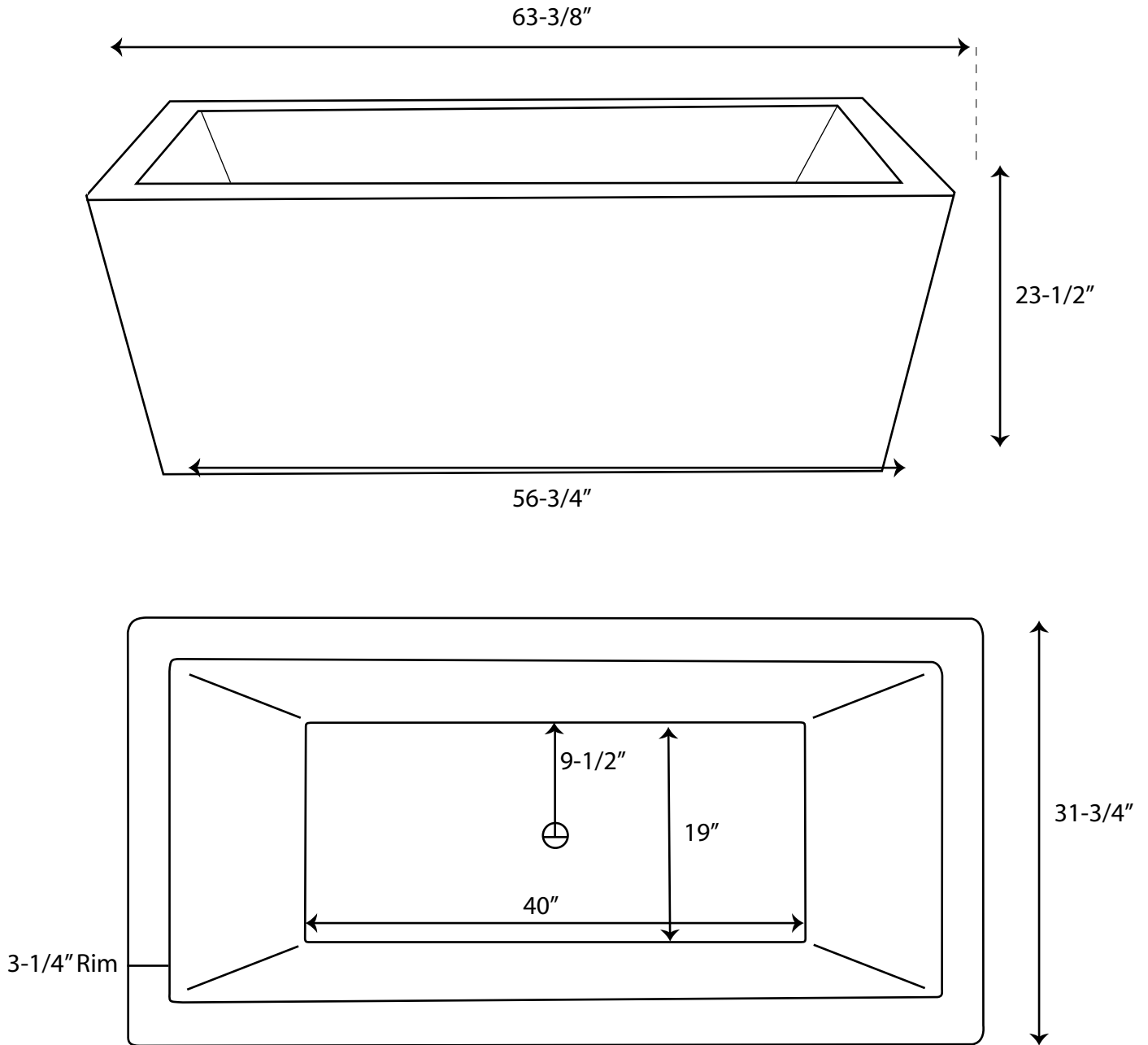

Tub is 18" deep at drain.

Tub has no overflow.

All measurements are approximate. Measurements may vary +/- 1/2".